

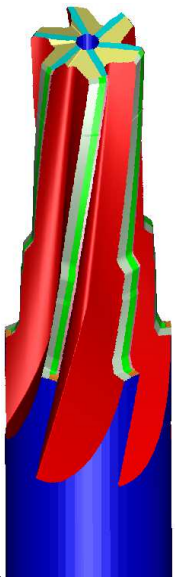

Con il Vostro ordine si intendono confermate le quote e le tolleranze presenti sul disegno.

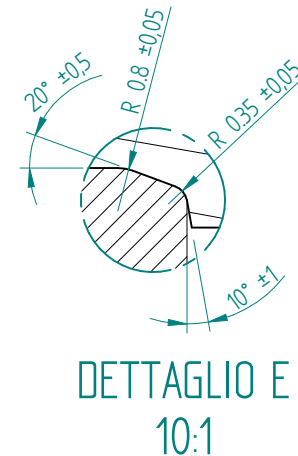
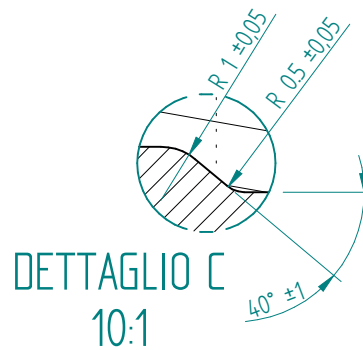
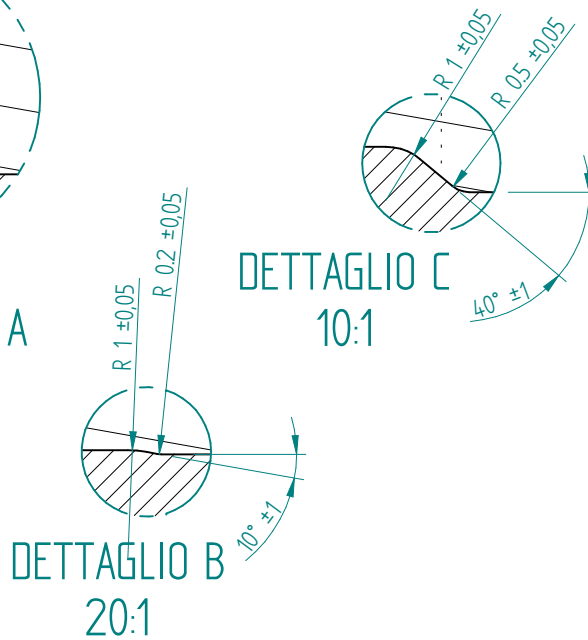
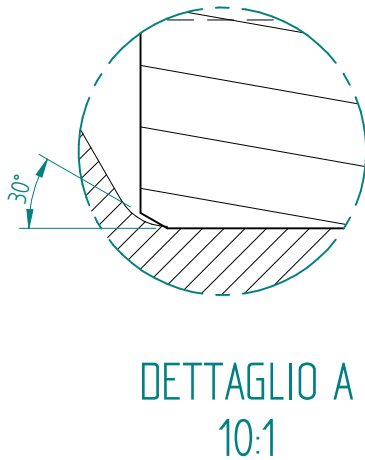
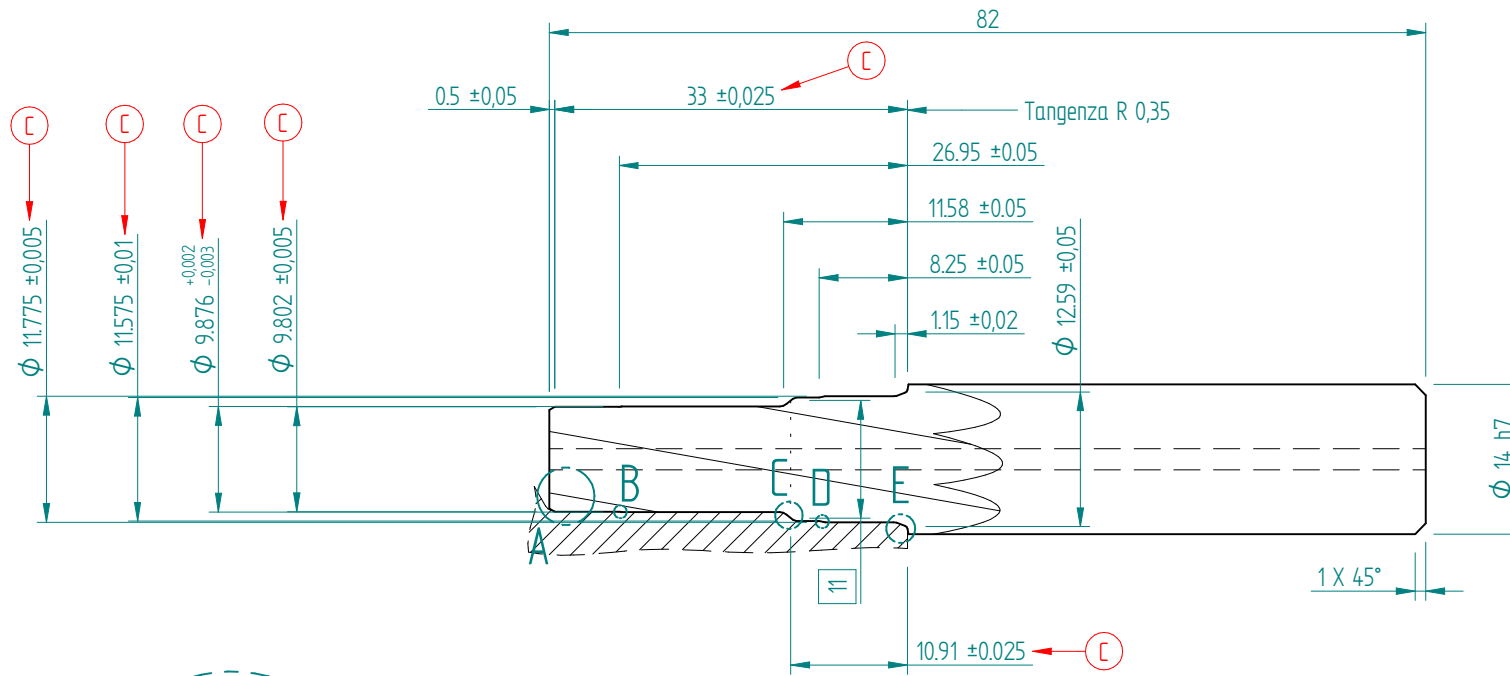

Elica Dx 10° z.6
Taglio Dx
Testa rastremata $0,5^\circ$
6 tagli al centro
foro centrale $\phi 2$

Revisioni:
7) Mod. L120 era L115 - $\phi 12,62$ era $\phi 12,59$ (Arturo 21/03/17)
8) Mod. $\phi 9,873$ era $\phi 9,876$ (Arturo 17/02/17)
9) Mod. $\phi 9,876 \pm 0,003$ era $\phi 9,873$ - agg. quota rif. 11 / $10,91 \pm 0,025$ - mod. alcune tolleranze -
aggiunte riferimenti: quote da certificare (C) (Arturo 03/11/17)
10) Mod. L115 era L12 - $\phi 12,59$ era $\phi 12,62$ (Arturo 21/11/17)

Scala: 2 : 1	Disegnatore: Arturo	Approvato:	Data: 03/07/20	Nome file: P5601_10.dft
Cliente:		Materiale: MD FC	Operazioni supplementari: Riv. Wonder Top	
 ABTools Costruzioni Utensili Speciali		Descrizione: Alesatore speciale - finitore		
		Cod. Cliente:	Cod. ABTools: P5601	Rev.: 10